

# MJ Series - Spare Transmitter

## Introduction

Spare transmitters are supplied without a code key - the small serial-number module that sets the ID number of the unit. The ID number is set this way (rather than DIP switches) to satisfy the requirement of AS1418 that the address detection mechanism be failsafe and tamperproof. It is not possible to incorrectly set the ID number (deliberately or accidentally) and control the wrong crane.

## To put a Spare Transmitter into Service

- Open the original transmitter
- Note the DIP switch settings (which set the frequency, whether the timeout is active/inactive, and if the horn sounds on low battery)
- Working in the bottom housing, remove the screws securing the circuit board to the case, and remove it. Loosen the locknut on the keyswitch and withdraw it if necessary.
- Remove the screws securing the transmitter module to the main electronics card, and separate them.
- Remove the screw securing the code key and remove the module.

Fit the code key into the spare transmitter, and set the DIP switches as per the original transmitter. Re-assemble and test.

## Notes:

If the original transmitter is lost, stolen, or completely destroyed, then the code keys must be replaced as a matched pair in the transmitter and receiver. For that reason, it may be useful to

## LOCATION OF SERIAL-NUMBER MODULE (CODE KEY)

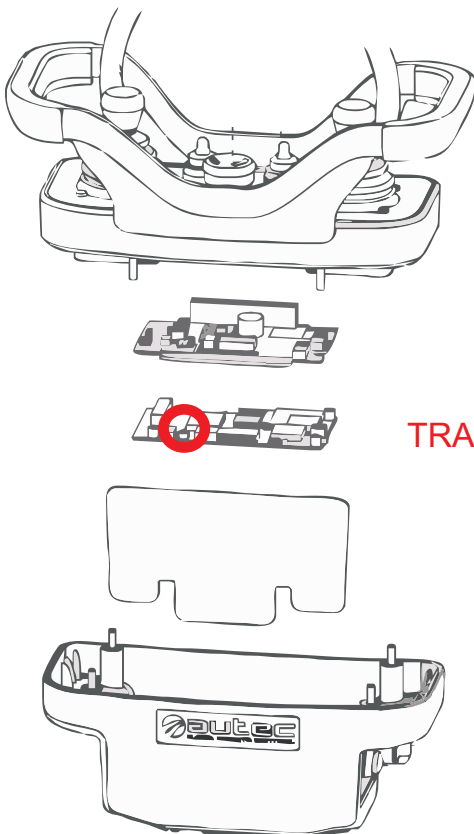

TRANSMITTER

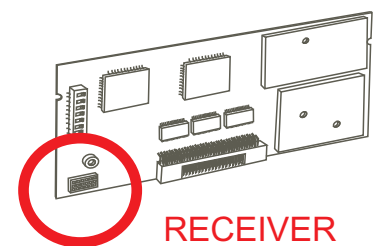

RECEIVER

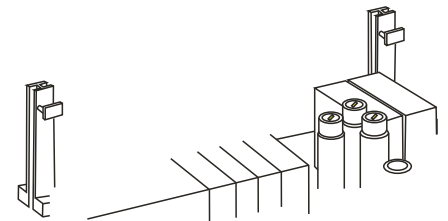

**industryIQ**

PO Box 5738  
Brendale DC QLD 4500  
Tel: 07 3889 9329  
Fax: 07 3889 9330  
support@industryiq.com.au